

Rivet Squeezers



Michigan Pneumatic

“Alligator” Yoke Riveters

Alligator type compression riveter has wide applications in many industries for squeezing a large variety of size and type of rivets. Strong squeeze action is easily controlled to provide uniformity and accuracy of work. Ideally used for dimpling, punching and pressing. Extra powerful, portable tandem cylinder also available with double the compressive force for larger riveting capacity. **Parts are interchangeable with Chicago Pneumatic 0214-A series riveters.**

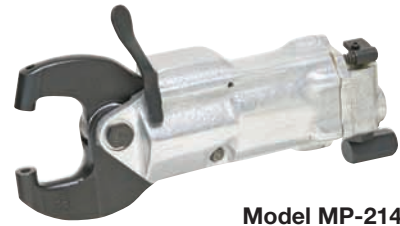

Model MP-2144A-112

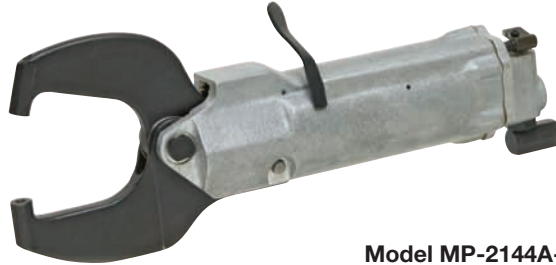

Model MP-2144A-TAN-3



Compression Riveters, “Alligator” Yoke

Model No.	Rivet Capacity		Yoke Reach	Yoke Gap	Closed Height	Shank Diameter	Max. Force	Max. Travel	Length	Weight w/Yoke
	Alum.	Steel								
MP-2144A-112	1/8"		1-1/2"	1-5/8"			3000 lbs.	5/8"	9-3/16"	3.75 lbs.
MP-2144A-214	1/8"	3/32"	2-1/4"	2-1/8"	7/8"	0.187"	2200 lbs.	7/8"	10-1/8"	4.25 lbs.
MP-2144A-3	3/32"		3"	2-1/8"			1800 lbs.	1-1/4"	10-7/8"	4.75 lbs.

Tandem Compression Riveters, “Alligator” Yoke

Model No.	Rivet Capacity		Yoke Reach	Yoke Gap	Closed Height	Shank Diameter	Max. Force	Max. Travel	Length	Weight w/Yoke
	Alum.	Steel								
MP-2144A-TAN-112	3/16"	5/32"	1-1/2"	1-5/8"	7/8"	0.187"	6000 lbs.	5/8"	12"	5.50 lbs.
MP-2144A-TAN-214	5/32"	1/8"	2-1/4"	2-1/8"	7/8"	0.187"	4300 lbs.	7/8"	13"	6.00 lbs.
MP-2144A-TAN-3	1/8"	3/32"	3"	2-1/8"			3400 lbs.	1-1/4"	13-3/4"	6.25 lbs.

Michigan Pneumatic

“C” Yoke Riveters

Specially designed for airplane construction to ensure fast, economical riveting where two-man operation is impractical. Features strong, steady, silent squeeze action, which is easily controlled for a large variety of rivets. Ideal for dimpling, punching, stamping and pressing. Widely used for truck, bus and automotive applications. Extra powerful, portable tandem cylinder also available with double the compressive force for larger riveting capacity. **Parts are interchangeable with Chicago Pneumatic 0214-C series riveters.**

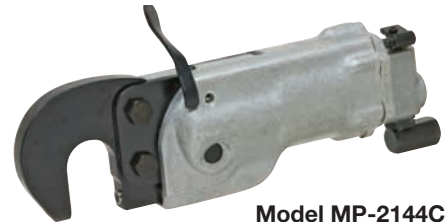

Model MP-2144C-112

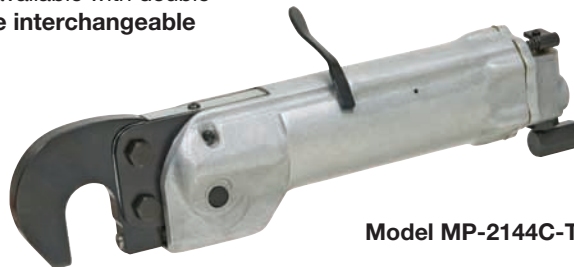

Model MP-2144C-TAN-112



Compression Riveters, “C” Yoke

Model No.	Rivet Capacity		Yoke Reach	Yoke Gap	Closed Height	Shank Diameter	Max. Force	Max. Travel	Length	Weight w/Yoke
	Alum.	Steel								
MP-2144C-112			1-1/2"							
MP-2144C-2	1/8"	3/32"	2"	1-1/4"	11/16"	0.187"	3000 lbs.	9/16"	10-5/16"	4.5 lbs.
MP-2144C-212			2-1/2"							
MP-2144C-3			3"							

Tandem Compression Riveters, “C” Yoke

Model No.	Rivet Capacity		Yoke Reach	Yoke Gap	Closed Height	Shank Diameter	Max. Force	Max. Travel	Length	Weight w/Yoke
	Alum.	Steel								
MP-2144C-TAN-112			1-1/2"							
MP-2144C-TAN-2	3/16"	5/32"	2"	1-1/4"	11/16"	0.187"	6000 lbs.	9/16"	14"	5.5 lbs.
MP-2144C-TAN-212			2-1/2"							
MP-2144C-TAN-3			3"							

Rivet Squeezers



Michigan Pneumatic

“Alligator” Yoke Riveters

Designed for one-man operation to increase productivity where costly two-man riveting was once done. Used in high volume riveting applications. Capable of accurately squeezing a large variety of solid, tubular and semi-tubular rivets in aircraft, truck, bus, boat, toy and automotive component applications. A tandem cylinder doubles the compressive force of the standard tool, allowing the operator to upset larger size rivets, as well as rivets made of stronger material. **All models: Plain backhead; 1/4" (NPTF) air inlet thread. MP-351: Short stroke adjustment; CR-1 rivet shank holes. Model 351FCT08 foot pedal control available.**



MP-351A-278



Compression Riveters, “Alligator” Yoke

Model No.	Rivet Capacity		Yoke Reach	Yoke Gap	Closed Height	Shank Diameter	Max. Force	Max. Travel	Length	Weight w/Yoke
	Alum.	Steel								
MP-351A-918	1/8"	3/32"	9-1/8"	2-3/16"	3/4"	0.187"	3000 lbs.	1-11/16"	25-3/4"	26.25 lbs.
MP-351A-7	1/8"	3/32"	7"	2"	1-1/2"		3000 lbs.	1-11/16"	23-5/8"	24.25 lbs.
MP-351A-5	1/8"	3/32"	5"	1-5/8"	7/8"		3400 lbs.	1-3/8"	21-5/8"	19.75 lbs.
MP-351A-278	5/32"	1/8"	2-7/8"	1-5/8"	7/8"		5200 lbs.	5/8"	19-1/2"	15.75 lbs.

Tandem Compression Riveters, “Alligator” Yoke

Model No.	Rivet Capacity		Yoke Reach	Yoke Gap	Closed Height	Shank Diameter	Max. Force	Max. Travel	Length	Weight w/Yoke
	Alum.	Steel								
MP-351A-TAN-918	3/16"	5/32"	9-1/8"	2-3/16"	3/4"	0.187"	6000 lbs.	1-11/16"	30"	29.00 lbs.
MP-351A-TAN-7	3/16"	5/32"	7"	2"	1-1/2"		6000 lbs.	1-11/16"	27-7/8"	27.00 lbs.
MP-351A-TAN-5	3/16"	5/32"	5"	1-5/8"	7/8"		6800 lbs.	1-3/8"	25-7/8"	22.50 lbs.
MP-351A-TAN-278	1/4"	3/16"	2-7/8"	1-5/8"	7/8"		10400 lbs.	5/8"	23-3/4"	18.50 lbs.

Michigan Pneumatic

“C” Yoke Riveters

Lightweight, compact, used extensively in electronic chassis, metal furniture, aircraft, automotive component, boat, truck and bus building applications. Can also be used for staking, stamping, pressing or crimping service. Air inlet swivel aids maneuverability. Squeezes uniformly every time trigger is actuated, independent of operator skill. Using a compressing tool ensures all joints are of the highest integrity. **All models: Plain backhead; 1/4" (NPTF) air inlet thread. CR-1 rivet shank holes; MP-351: Short stroke adjustment. Model 351FCT08 foot pedal control available.**



MP-351C-218



Compression Riveters, “C” Yoke

Model No.	Rivet Capacity		Yoke Reach	Yoke Gap	Closed Height	Shank Diameter	Max. Force	Max. Travel	Length	Weight w/Yoke
	Alum.	Steel								
MP-351C-218	3/16"	5/32"	2-1/8"	1-3/16"	25/32"	0.187"	6000 lbs.	9/16"	17-1/2"	12.50 lbs.

Tandem Compression Riveters, “C” Yoke

Model No.	Rivet Capacity		Yoke Reach	Yoke Gap	Closed Height	Shank Diameter	Max. Force	Max. Travel	Length	Weight w/Yoke
	Alum.	Steel								
MP-351C-TAN-218	1/4"	7/32"	2-1/8"	1-3/16"	25/32"	0.187"	12000 lbs.	9/16"	21-3/4"	15.25 lbs.

Other yokes also available. See pages 94-97 for accessories.

Rivet Squeezer Accessories



MP-351C & CP-0351 Series "C" Yokes

Fits standard Type 1 frame.

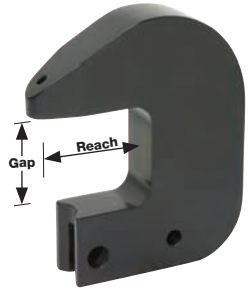

No.	Reach	Gap
016	1-3/16"	2-5/8"
017	3-1/2"	1-1/4"
018	2"	2"
019	5"	2-1/2"
020	2-1/8"	1-3/16"

CP-0355 Series "C" Yokes

Includes bronze set holder bushings.

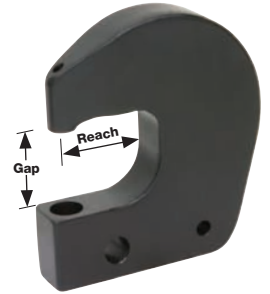

No.	Reach	Gap
P089777	2-1/8"	1-7/8"
P093213	4-1/2"	1-15/16"

MP-2144C & CP-0214 Series "C" Yokes

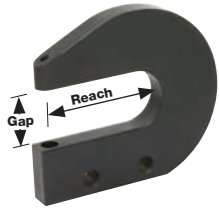

No.	Reach	Gap
001	1-1/2"	1-1/4"
002	2"	1-1/4"
003	2-1/2"	1-3/8"
004	3"	1-3/8"
005	2-3/4"	1-3/16"
006	1-3/4"	1-1/4"
007	1-3/16"	1-3/16"
012XP	3"	1-1/2"

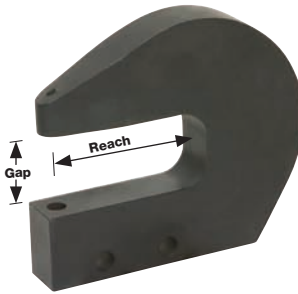

Heavy-Duty Model

No.	Reach	Gap
008	3-7/8"	1-3/16"
009	5-5/8"	1-3/16"
010	5-3/8"	1-1/4"

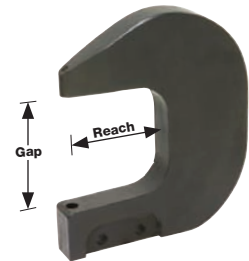

Heavy-Duty Model

No.	Reach	Gap
011	2-1/2"	2"
012	3"	1-1/2"
013	3"	3"
014	3"	3-1/2"
015	3-1/2"	2"

Michigan Pneumatic Model 351CON

Riveter Conversion Unit

Conversion unit fits all "Alligator" or "C" type models MP-351 and CP-0351 compression riveters. Increases rivet capacity from 3/16" Dural to 5/16", and 5/32" steel to 1/4".



Michigan Pneumatic Model 351RY

Roof Top Rail Yoke

Fits MP-351 and CP-0351 "C" series riveters with Type 1 frames. Ideal for installing 3/16" and 1/4" rivets on most tractor trailer roof rails. **Requires at least SM210 flush set for the top of yoke and choice of additional cupped rivet set to be inserted in the moving set holder.**

P003092RY	5/16"-24 Bolt
P073047RY	7/16"-20 Bolt
P003093	5/16"-24 Nylock Nut
P006315	7/16"-20 Nylock Nut

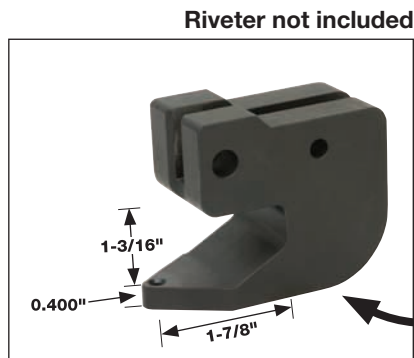



Air-Operated Pedal Control

Converts standard lever-operated compression riveters to foot-operated for riveting applications where both hands are required to stabilize the product being riveted.

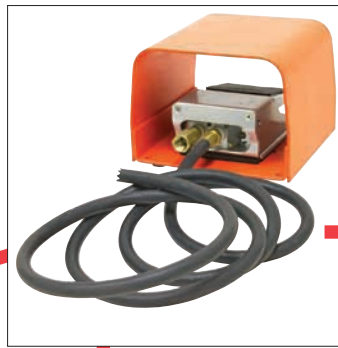

Model 2144FCT

Can be installed on the following model riveters: **MP-2144**, **CP-0214**, **USI-114** and other riveters of the same design.

Includes a 6' hose assembly from the foot pedal to the back cap.



Model 351FCT08

Can be installed on the following model riveters: **MP-351**, **CP-0351**, **USI-151** and **APT-740**.

Includes an 8' hose assembly from the foot pedal to the air valve and air intake.



Model 450FCT

Can be installed on the following model riveters: **CP-0450** and **USI-150**.

Comes with a 10' hose assembly from the foot pedal to the air valve and a 5' hose assembly from the air valve to the back cap. Includes all necessary hardware to mount the air valve and back cap.



Model 450EAFCT

Can be installed on the following model riveters: **CP-0450EA**, **USI-150EA** and **Zephyr ZP450EA**.

Comes with a 10' hose assembly from the foot pedal to the air valve and a 5' hose assembly from the air valve to the back cap. Includes all necessary hardware to mount the air valve and back cap.

Michigan Pneumatic Model P078666G

Cable-Operated Pedal Control

Allows standard lever-operated CP-0450 compression riveters to foot-operated applications requiring two hands.

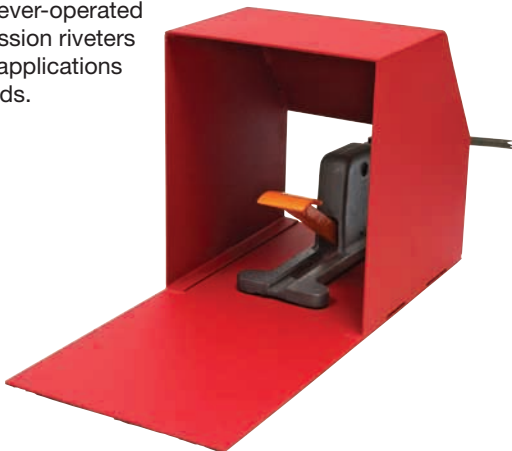

Michigan Pneumatic Model P078214G

Cable-Operated Pedal Control

Allows standard lever-operated CP-0351 & CP-0355 compression riveters to foot-operated applications requiring two hands. Includes lever conversion kit.

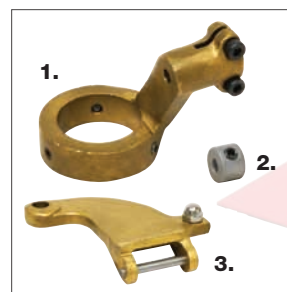

1. **P074830** Cable Casing Bracket
2. **P074827** Cable Collar
3. **P074831** Throttle Lever

Rivet Squeezer Accessories



Michigan Pneumatic Model 2144APS

Air-Operated, Foot-Controlled Pedestal Stand

The 2144APS Pedestal Stand is used with the MP-2144, CP-214, or U.S. 114 Compression Riveters. This Bench Top Stand comes with the 2144FCT Air Foot Pedal Control Assembly that has a 6 ft. hose and has a working height of 12". This provides a hands-free option where components require both hands for stability.



Riveter not included.

Michigan Pneumatic Model 351APS

Air-Operated, Foot-Controlled Pedestal Stand

The 351APS pedestal stand is used with the CP-0351, U.S. 151, or APT 740 Compression Riveters. This stand comes with the 351FCT08 Air Foot Pedal Control Assembly that has 8 ft. hoses and has a working height of 41". This provides a hands-free option where components require both hands for stability.



Riveter not included.

Michigan Pneumatic

CP-0450 Pressure Pad Dolly



Model No.	Description
P078691	3/8" Pressure Pad Dolly
P078692	1/2" Pressure Pad Dolly

Michigan Pneumatic

CP-0450EA Shank Adapters

Allows standard CP-0450EA riveter to accept MP-351 & CP-0351 rivet squeezer rivet sets.



Model No.	Description
P081392	0.1875" Shank adapter
P081393	0.250" Shank Adapter
P082189	0.3125" Shank Adapter
P082190	0.375" Shank Adapter

Michigan Pneumatic

CP-0450EA Flush Sets



Model No.	Description
P081391	23/64" Flush Set
P085110	23/64" Flush Set, 3-1/2 Long
P081390	31/64" Flush Set
P081389	39/64" Flush Set



.187" Rivet Sets

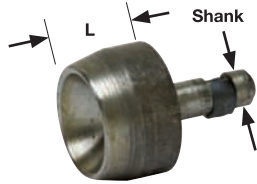

Squeeze Riveter Sets

No.	L
SM200	1/4"
SM201	3/8"
SM202	1/2"
SM203	5/8"
SM204	3/4"

For example, to order:
3/8" Long; 1/4" Button
Specify: SM201-4358

Description	Rivet Diameter				
	3/32"	1/8"	5/32"	3/16"	1/4"
Round AN430	4303	4304	4305	4306	4308
Flat AN442	4423	4424	4425	4426	4428
Brazier AN455	4553	4554	4555	4556	4558
Mod. Brazier AN456	4563	4564	4565	4566	4568
Universal AN470	4703	4704	4705	4706	4708
Button AN435	4353	4354	4355	4356	4358

Flush Sets

No.	L
SM210	1/8"
SM211	1/4"
SM212	3/8"
SM213	1/2"
SM214	5/8"
SM215	3/4"
SM217	1"

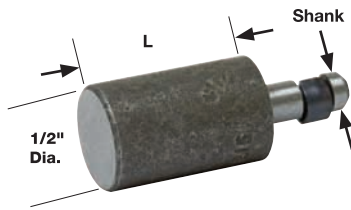

Tubular Rivet Set

No.	L
SM200	1/4"
SM201	3/8"
SM202	1/2"
SM203	5/8"
SM204	3/4"

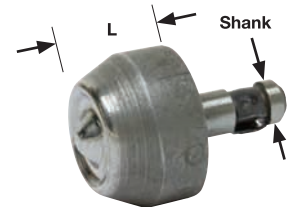

Spacer Shims

No.	A
SM-S0	1/64" (0.0156")
SM-S1	1/32" (0.0312")
SM-S2	1/16" (0.0625")

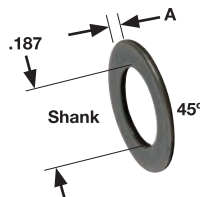

Tubular AN-450

Rivet Diameter				
3/32"	1/8"	5/32"	3/16"	1/4"
4503	4504	4505	4506	4508

.250"/.312"/.375" Rivet Sets

Squeeze Riveter Sets

Rivet sets can be furnished in 1/4", 3/8", 1/2", 5/8" and 3/4" lengths and shank sizes. Please specify shank size, length and rivet.

For example, to order:
1/4" Long; 1/8" Universal
Specify: SM220-4704

Description	Rivet Diameter						
	3/32"	1/8"	5/32"	3/16"	1/4"	5/16"	3/8"
Round AN430	4303	4304	4305	4306	4308	43010	43012
Flat AN442	4423	4424	4425	4426	4428	44210	44212
Brazier AN455	4553	4554	4555	4556	4558	45510	45512
Mod. Brazier AN456	4563	4564	4565	4566	4568	45610	45612
Universal AN470	4703	4704	4705	4706	4708	47010	47012
Button AN435	4353	4354	4355	4356	4358	43510	43512

.250 Shank

No.	L
SM220	1/4"
SM221	3/8"
SM222	1/2"
SM223	5/8"
SM224	3/4"

.312 Shank

No.	L
SM240	1/4"
SM241	3/8"
SM242	1/2"
SM243	5/8"
SM244	3/4"

.375 Shank

No.	L
SM260	1/4"
SM261	3/8"
SM262	1/2"
SM263	5/8"
SM264	3/4"

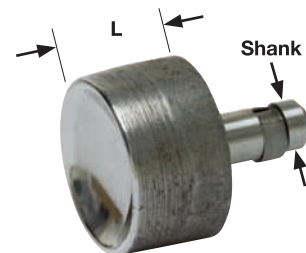

Flush Sets

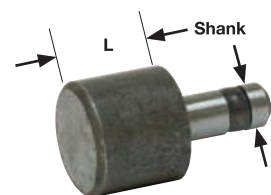

.250 Shank

No.	L
SM230	1/8"
SM231	1/4"
SM232	3/8"
SM233	1/2"
SM234	5/8"
SM235	3/4"
SM236	7/8"
SM237	1"

.312 Shank

No.	L
SM250	1/8"
SM251	1/4"
SM252	3/8"
SM253	1/2"
SM254	5/8"
SM255	3/4"
SM256	7/8"
SM257	1"

.375 Shank

No.	L
SM270	1/8"
SM271	1/4"
SM272	3/8"
SM273	1/2"
SM274	5/8"
SM275	3/4"
SM276	7/8"
SM277	1"

Some rivet/flush sets may require a six-piece minimum order. Please call for availability.