

Linear potentiometers Standard series

- Measuring range 30 - 1250 mm
- Long mechanical life 100 million cycles
- Excellent repeatability <0.01 mm
- Infinite resolution
- 5 KOhm or 10 KOhm



Technical specifications

Measurement stroke	30 to 1250 mm
Linearity	± %0,05 (>200mm), ±%0,1 (130-200mm), ±%0,2 (75 - 130mm), ±%0,5 (<75mm)
Repeatability	< 0.01 mm
Resolution	Infinite
Resistance	5 KOhm or 10 KOhm
Resistance tolerance	± %20
Load resistance	100 KOhm min.
Recommended cursor current	< 1 µA
Permissible applied voltage	28 VDC max.
Electrical connections	4 pin connector
Displacement speed	< 5 m/s
Mechanical life	100 million cycles
Case dimensions	33 mm x 33 mm
Case material	Anodized aluminium
Rod material	Stainless steel
Rod diameter	Ø6 mm
Mechanical fixing	Variable brackets
IP degree	IP 65
Operating temperature	-20°C ... +80°C
Storage temperature	-30°C ... +90°C

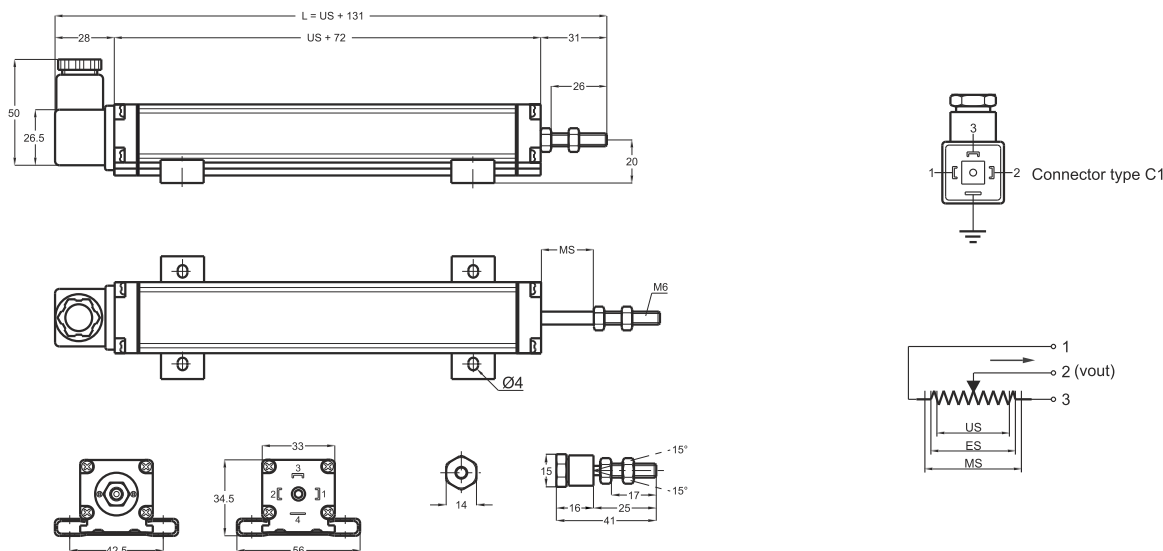

LPT (mm)	30	50	75	100	125	130	150	175	200	225	250	275	300	325	350	375	400	450	500	550	600	650	700	750	800	850	900	1000	1250
US (Usefull Stroke)	30	50	75	100	125	130	150	175	200	225	250	275	300	325	350	375	400	450	500	550	600	650	700	750	800	850	900	1000	1250
MS (Mechanical Stroke)	33	53	73	103	128	133	153	178	203	228	253	278	303	328	353	373	403	453	503	553	603	653	703	753	803	853	903	1003	1253
L (Total Length)	161	181	206	231	256	261	281	306	331	356	381	406	431	456	481	506	531	581	631	681	731	781	831	881	931	981	1031	1131	1381

Model	Measurement stroke (mm)	Linearity (%)	Resistance (KOhm)	Connector / Cable
(example) LPT	500	D	5K	C1
LPT	30 ... 1250 mm	D : ± %0,05 (standard)	5K : 5 KOhm 10K : 10 KOhm	C1 : 4 pin connector