

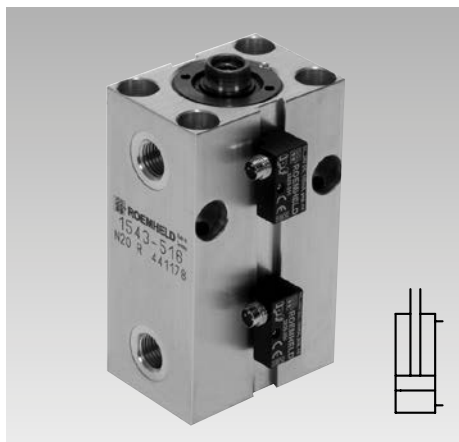

Block Cylinder

with aluminium housing for adjustable magnetic sensors, double acting, max. operating pressure 350 bar



Oil supply

Versions with pipe thread see page 2

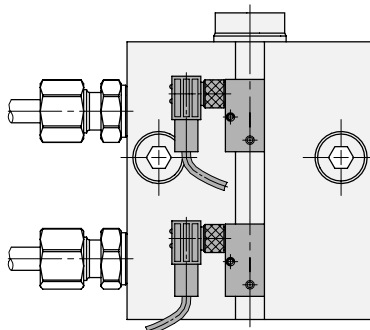

Manifold mounting with O-ring sealing see page 3

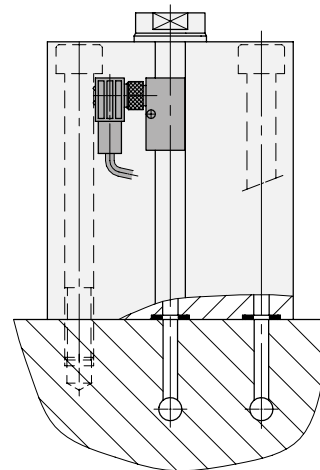

Application

Double-acting block cylinders with position monitoring are particularly suitable for automated installations, time and cycle-dependent clamping and unclamping.

Description

The position monitoring supplies the required information about the position of the piston. Monitoring is made by electronic sensors which detect the magnetic field of the magnetic piston. The switching points can be continuously adjusted by displacement of the switches in the slots.

Advantages

- Compact design
- Easy adjustment of switching point positions
- Same dimensions as the block cylinders as per data sheet B 1.5094, except for total length.
- Diverse mounting possibilities
- 3 standard stroke lengths

Throttling of the flow rate

Throttling has to be made in the oil supply line to the block cylinder to rule out a possible pressure intensification and thereby pressures over 350 bar. The hydraulic circuit diagram shows flow control valves which allow oil return from the block cylinder without any impediments.

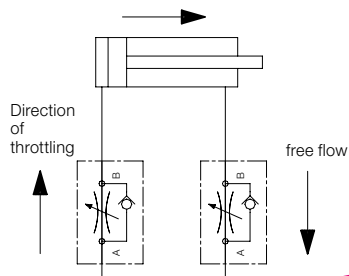

Important notes

Please only use fittings with soft seals, see page 4.

Block cylinders with aluminium housing are **not suitable for operation of blanking and punching dies.** Uncontrollable spikes and vibrations can appear which especially in the case of aluminium could cause a decrease in tool life.

Steel can influence the magnetic field of the magnetic piston and thereby the position of the switching points. If there is the same influence for each stroke (e.g. because of adjoining steel components) it can be compensated by displacing the magnetic sensors. But if the influence differs from stroke to stroke, as e.g. in the case of swarf, a cover has to be provided 30 mm over the magnetic sensors.

Covers have to be provided to protect the cylinders against ferritic swarf.

Piston material: case-hardening steel, hardened
Cylinder body material: anodized aluminium alloy

Corrosion-resistant version is available on request

For part-nos. see page 2 bottom

Max. cylinder temperature see page 4

Operating conditions, tolerances and other data see data sheet A 0.100.

Fixing possibilities

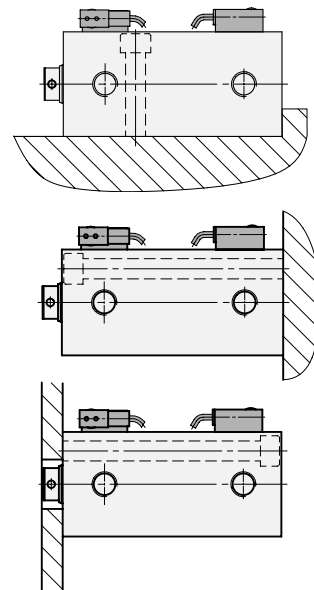

Application example of mould construction



Variants available:
 ◆ Shorter stroke
 ◆ Keyway
 ◆ Internal thread instead of mounting holes in the body
 Corrosion-resistant version available

Versions with pipe thread

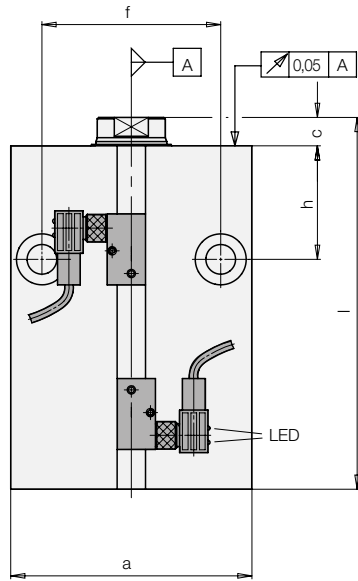
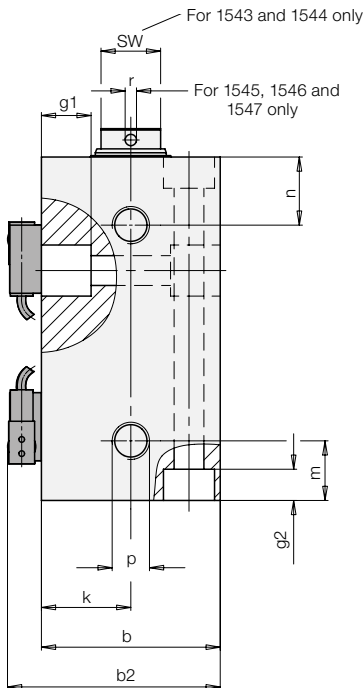

Accessory: Magnetic sensors see reverse page

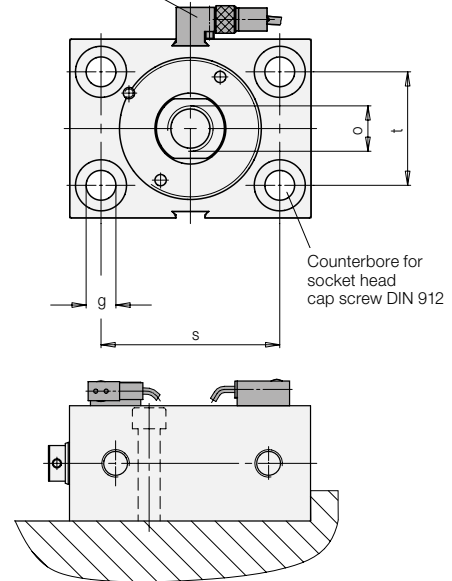

Cylinders must be backed up for operating pressures exceeding 160 bar.

| | | | | | | |
|-----------------------------|-------------------|--------------------|----------|----------|----------|----------|
| Piston Ø D | [mm] | 25 | 32 | 40 | 50 | 63 |
| Rod Ø d | [mm] | 16 | 20 | 25 | 32 | 40 |
| Force to push | at 100 bar | [kN] | 4.9 | 8.0 | 12.5 | 31.2 |
| | at 350 bar | [kN] | 17.1 | 28.1 | 44 | 109.2 |
| Force to pull | at 100 bar | [kN] | 2.9 | 4.9 | 7.7 | 18.6 |
| | at 350 bar | [kN] | 10.1 | 17.1 | 26.8 | 65.1 |
| Oil volume per 10 mm stroke | Stroke to extend | [cm ³] | 4.91 | 8.05 | 12.56 | 31.17 |
| | Stroke to retract | [cm ³] | 2.9 | 4.9 | 7.7 | 18.6 |
| a | [mm] | 65 | 75 | 85 | 100 | 125 |
| b | [mm] | 45 | 55 | 63 | 75 | 95 |
| b2 | [mm] | 57 | 67 | 75 | 87 | 107 |
| c | [mm] | 7 | 10 | 10 | 10 | 14 |
| f | [mm] | 50 | 55 | 63 | 76 | 95 |
| g | [mm] | 8.5 | 10.5 | 10.5 | 13 | 17 |
| g1 at both sides | [mm] | 12 | 16 | 17 | 22 | —* |
| g2 at both sides | [mm] | 9 | 11 | 11 | 13 | 17 |
| h | [mm] | 33 | 38 | 40 | 44 | 50 |
| k | [mm] | 22.5 | 27.5 | 31.5 | 37.5 | 47.5 |
| m | [mm] | 18 | 20 | 21 | 21 | 26 |
| n | [mm] | 18 | 22 | 24 | 27 | 26 |
| o x depth of thread | [mm] | M10 x 15 | M12 x 15 | M16 x 25 | M20 x 30 | M27 x 40 |
| p | | G 1/4 | G 1/4 | G 1/4 | G 1/4 | G 1/2 |
| r | [mm] | — | — | 4 | 4 | 4 |
| s | [mm] | 50 | 55 | 63 | 76 | 95 |
| t | [mm] | 30 | 35 | 40 | 45 | 65 |
| SW | [mm] | 13 | 17 | — | — | — |

| | | | | | | |
|--|-------------|----------------|----------------|----------------|----------------|----------------|
| Stroke ±1 | [mm] | 20 | 25 | 25 | 25 | 30 |
| Total length l ±1 | [mm] | 85 | 100 | 106 | 117 | 135 |
| Weight | [kg] | 0.63 | 1.02 | 1.4 | 2.04 | 4.0 |
| Part no. (without magnetic sensors) | | 1543513 | 1544513 | 1545513 | 1546513 | 1547513 |

| | | | | | | |
|--|-------------|----------------|----------------|----------------|----------------|----------------|
| Stroke ±1 | [mm] | 50 | 50 | 50 | 50 | 63 |
| Total length l ±1 | [mm] | 115 | 125 | 131 | 142 | 168 |
| Weight | [kg] | 0.85 | 1.28 | 1.90 | 2.90 | 5.05 |
| Part no. (without magnetic sensors) | | 1543516 | 1544516 | 1545516 | 1546516 | 1547516 |

| | | | | | | |
|--|-------------|----------------|----------------|----------------|----------------|----------------|
| Stroke ±1 | [mm] | 100 | 100 | 100 | 100 | 100 |
| Total length l ±1 | [mm] | 165 | 175 | 181 | 192 | 205 |
| Weight | [kg] | 1.20 | 1.81 | 3.00 | 4.60 | 6.22 |
| Part no. (without magnetic sensors) | | 1543519 | 1544519 | 1545519 | 1546519 | 1547519 |

Part no.
154X4XX
154X2X

Version
corrosion-resistant
FKM seals see chart page 4

* Type 1547 without counterbores

Manifold mounting with O-ring sealing

Oil supply and O-ring sealing at:

Broad side
Stroke 20 – 30 mm
K

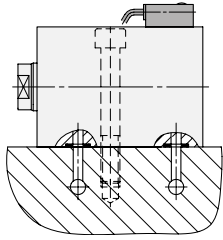

Broad side
Stroke 50 – 100 mm
L

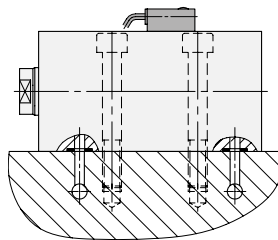

Rod side
S

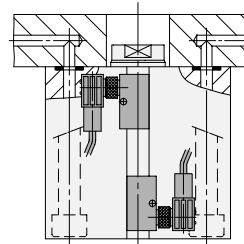

Bottom side
B

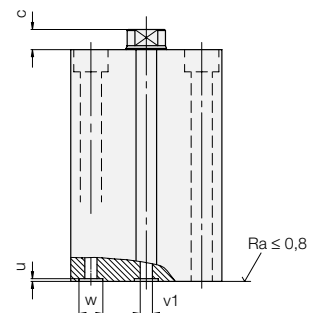
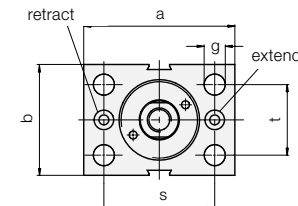
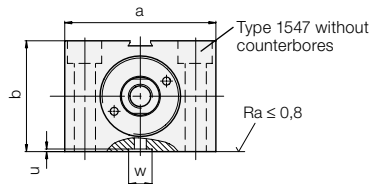
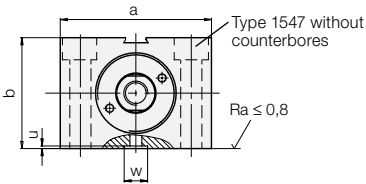
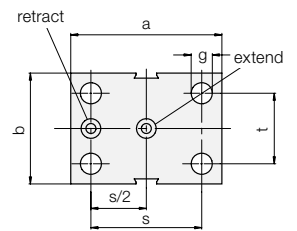
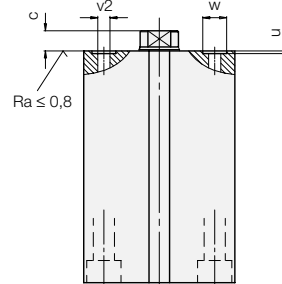
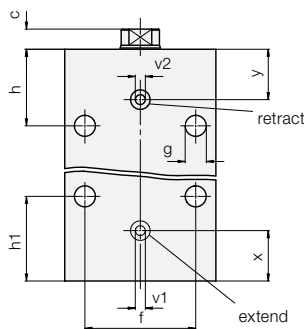
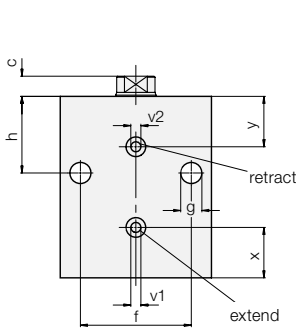
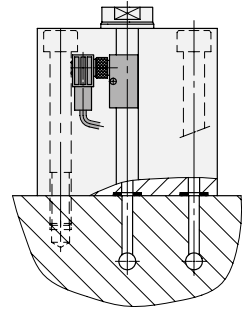

| Block Cylinder | | 1543XXX | 1544XXX | 1545XXX | 1546XXX | 1547XXX |
|------------------------------|------|----------------|----------------|----------------|----------------|----------------|
| Piston Ø | [mm] | 25 | 32 | 40 | 50 | 63 |
| Rod Ø | [mm] | 16 | 20 | 25 | 32 | 40 |
| a | [mm] | 65 | 75 | 85 | 100 | 125 |
| b | [mm] | 45 | 55 | 63 | 75 | 95 |
| c | [mm] | 7 | 10 | 10 | 10 | 14 |
| f | [mm] | 50 | 55 | 63 | 76 | 95 |
| g | [mm] | 8.5 | 10.5 | 10.5 | 13 | 17 |
| h | [mm] | 33 | 38 | 40 | 44 | 50 |
| h1 | [mm] | 40 | 42 | 44 | 47 | 60 |
| s | [mm] | 50 | 55 | 63 | 76 | 95 |
| t | [mm] | 30 | 35 | 40 | 45 | 65 |
| u ± 0.05 | [mm] | 1.1 | 1.1 | 1.1 | 1.1 | 1.3 |
| v1 | [mm] | 4 | 5 | 6 | 6 | 8 |
| v2 | [mm] | 4 | 4.5 | 4.5 | 6 | 6 |
| w + 0.2 | [mm] | 9.8 | 10.8 | 10.8 | 10.8 | 15.8 |
| x | [mm] | 21.5 | 25 | 27 | 30 | 35 |
| y | [mm] | 21 | 25 | 27 | 29.5 | 32 |
| Dimensions O-ring | [mm] | 7 x 1.5 | 8 x 1.5 | 8 x 1.5 | 8 x 1.5 | 12.42 x 1.78 |
| Part no. spare O-ring | | 3000342 | 3000343 | 3000343 | 3000343 | 3000335 |
| Part no. O-ring (FKM) | | 3001077 | 3000275 | 3000275 | 3000275 | 3001152 |

O-rings are included in delivery.

Other dimensions see page 2.

Order:

Please add the identification letters **K, L, S, or B** to the Part no. of the required block cylinder.

Example of ordering:

Double-acting block cylinder 1545513 with oil supply at the broad side
Part no. 1545513 K

Accessory: Magnetic sensors

Compared with traditional reed switches the electronic magnetic sensors offer the following advantages:

- Indifference to shock and vibration
- Bounce-free output signal
- Only one switching point
- Wear resistant
- Protection against reverse battery
- Protected against short circuits

Electric connection is made as per traditional inductive proximity switches; up to four magnetic sensors can be connected in series.

Minimum distance of the switching points: 6 mm.

For further information about voltage supply for position controls see data sheet G 2.410.

Electronic magnetic sensor

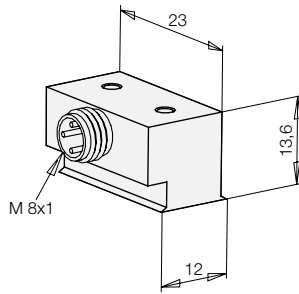

Temperature curve

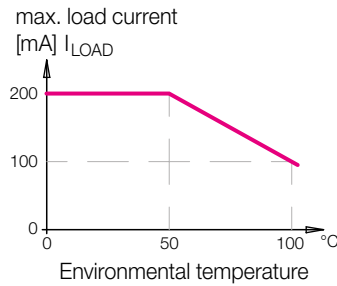

Connecting cable with right angle plug

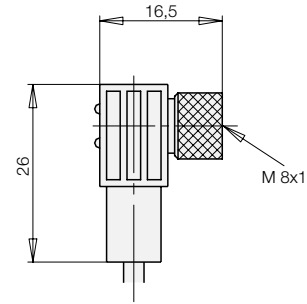

Connecting scheme

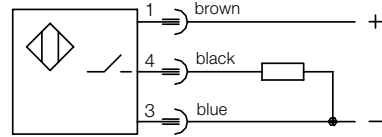

pnp (+) switching

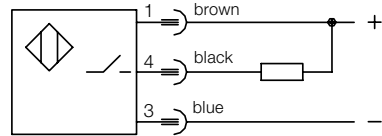

npn (-) switching

Technical data

Cylinder body material
Voltage
Residual ripple
Current load I_{LOAD}

Electronic magnetic sensor

aluminium black lacquered
10 – 30 V DC
max. 10%
200 mA – up to 50 °C
150 mA – at 75 °C
100 mA – at 100 °C

Connecting cable with right angle plug

10 – 30 V DC

Current consumption
Voltage drop (max. load)
Protected against short circuits
Protection against reverse battery
Switching frequency
Switching hysteresis
Protection as per DIN 40050
Environmental temperature
Plug connection
LED

< 15 mA
< 2 V
yes
installed
1 kHz
3 mm
IP 67
–25 °C up to +100 °C
M8 plug
no

IP 67
–25 °C up to +90 °C
M8 plug
Voltage (green)
Function display (yellow)
PUR, 5 m

Cable, length of cable

Output, interlock

Part no. (1 off)

pnp

3829234

npn

3829240

pnp

3829099

npn

3829 124

Note:

Electronic magnetic sensors for an environmental temperature of +120 °C or with short path are available on request.

Further accessory

see data sheet G 2.140

- Pin-and-socket connector
- Y-distributor
- Reversing plug
- Voltage regulator
- Straight tube male stud coupling with elastic sealing

Max. cylinder temperature

| Hydraulic fluid | Cylinder temperature | with magnetic sensor | without magnetic sensor | |
|-----------------|----------------------|----------------------|-------------------------|-----------------|
| | | | Perbunan | FKM |
| HLP | –25 ... +100 °C | | –25 ... +100 °C | –20 ... +120 °C |
| HFD | | | | –20 ... +120 °C |

Type L

D 8 L ED for tube Ø 8 G 1/4 250 bar

D 15 L ED for tube Ø 15 G 1/2 250 bar

Part no.

9208 131

9215033

Type S

D 8 S ED for tube Ø 8 G 1/4 500 bar

D 16 S ED for tube Ø 16 G 1/2 500 bar

Part no.

9208 132

9216021



Other fittings see data sheet F 9.300.