

8V1045.00-2

1 General information

- Modular mechanical design using plug-in modules
- Integrated line filter
- Integrated braking resistor
- All connections are made using plug-in connectors
- Integrated electronic restart inhibit

2 Order data

Model number	Short description	Figure
	Servo drives	
8V1045.00-2	ACOPOS servo drive, 3x 400-480 V, 4.4 A, 2 kW, line filter, integrated braking resistor and electronic secure restart inhibit	
	Optional accessories	
	Plug-in modules	
8AC110.60-3	ACOPOS plug-in module, CAN interface	
8AC114.60-2	ACOPOS plug-in module, POWERLINK V2 interface	
8AC120.60-1	ACOPOS plug-in module, EnDat encoder and sine incremental encoder interface	
8AC121.60-1	ACOPOS plug-in module, HIPERFACE interface	
8AC122.60-3	ACOPOS plug-in module, resolver interface 10 kHz	
8AC123.60-1	ACOPOS plug-in module, incremental encoder and SSI absolute encoder interface	
8AC125.60-1	ACOPOS plug-in module, BiSS encoder interface 5 V	
8AC125.60-2	ACOPOS plug-in module, BiSS encoder interface 5 V, baud rate 6.25 Mbit/s	
8AC125.61-2	ACOPOS plug-in module, BiSS encoder interface 12 V, baud rate 6.25 Mbit/s	
8AC126.60-1	ACOPOS plug-in module, EnDat 2.2 encoder interface	
8AC130.60-1	ACOPOS plug-in module, 8 digital I/O configurable in pairs as 24 V input or as output 400/100 mA, 2 digital outputs 2 A, order TB712 terminal block separately	
8AC131.60-1	ACOPOS plug-in module, 2 analog inputs ± 10 V, 2 digital I/O points configurable as 24 V input or 45 mA output, order TB712 terminal block separately	
8AC140.60-3	ACOPOS plug-in module, CPU, x86 100 MHz Intel compatible, 32 MB DRAM, 32 kB SRAM, removable application memory: CompactFlash, 1 CAN interface, 1 Ethernet interface 100 Base-T, 1 PROFIBUS DP slave interface, 1 RS232 interface, 3 digital I/O points configurable as 24 VDC input or 500 mA output, 1 analog input ± 10 V, order program memory and 0TB708 terminal block separately	
8AC140.61-3	ACOPOS plug-in module, CPU, ARNC0, x86 100 MHz Intel compatible, 32 MB DRAM, 32 kB SRAM, removable application memory: CompactFlash, 1 CAN interface, 1 Ethernet interface 100 Base-T, 1 PROFIBUS DP slave interface, 1 RS232 interface, 3 digital I/O points configurable as 24 VDC input or 500 mA output, 1 analog input ± 10 V, order program memory and 0TB708 terminal block separately	
8AC141.60-2	ACOPOS plug-in module, CPU, x86 100 MHz Intel compatible, 16 MB DRAM, 32 kB SRAM, removable application memory: CompactFlash, 2 CAN interfaces, 1 Ethernet interface 100 Base-T, 1 RS232 interface, 1 X2X Link Master interface, 3 digital I/O points configurable as 24 VDC input or 500 mA output, 1 analog input ± 10 V, order program memory and 0TB704 and 0TB708 terminal blocks separately	
8AC141.61-3	ACOPOS plug-in module, CPU, ARNC0, x86 100 MHz Intel compatible, 32 MB DRAM, 32 kB SRAM, removable application memory: CompactFlash, 2 CAN interfaces, 1 Ethernet interface 100 Base-T, 1 RS232 interface, 1 X2X Link Master interface, 3 digital I/O points configurable as 24 VDC input or 500 mA output, 1 analog input ± 10 V, order program memory and 0TB704 and 0TB708 terminal blocks separately	

Table 1: 8V1045.00-2 - Order data

Model number	Short description	Figure
8X0010.00-1	Shielding component sets ACOPOS shielding components set for 8V1022.xxx-x up to 8V1090.xxx-x	
	Terminal sets	
8X0001.00-1	ACOPOS accessories, plug set for 8V1010.00 and 8V1090.00 (3 phase)	

Table 1: 8V1045.00-2 - Order data

3 Technical data

Product ID	8V1045.00-2
General information	
B&R ID code	0x12C7
Slots for plug-in modules	4
Certification	
CE	Yes
cULus	Yes
KC	Yes
FSC	Yes
Mains connector	
Permissible power mains forms	TT, TN ¹⁾
Mains input voltage	3x 400 VAC to 480 VAC $\pm 10\%$ 3x 230 VAC $\pm 10\%$ ²⁾
Frequency	50 / 60 Hz $\pm 4\%$
Installed load	Max. 5 kVA
Starting current at 400 VAC	7 A
Switch-on interval	>10 s
Integrated line filter in accordance with EN 61800-3, Category C3 ³⁾	Yes
Power loss at max. device power without braking resistor	Approx. 180 W
DC bus connection	
DC bus capacitance	235 μ F
24 VDC supply	
Input voltage ⁴⁾	24 VDC $\pm 25\%$
Input capacitance	8200 μ F
Current consumption ⁵⁾	Max. 2.5 A + current for motor holding brake
Motor connection	
Quantity	1
Continuous current ⁶⁾	4.4 A _{eff}
Reduction of continuous current depending on the ambient temperature	
Mains input voltage: 400 VAC	
Switching frequency 5 kHz	No reduction
Switching frequency 10 kHz	No reduction
Switching frequency 20 kHz	0.13 A _{eff} per °C (starting at 45°C) ⁷⁾
Mains input voltage: 480 VAC	
Switching frequency 5 kHz	No reduction
Switching frequency 10 kHz	No reduction
Switching frequency 20 kHz	0.13 A _{eff} per °C (starting at 35°C) ⁷⁾
Reduction of continuous current depending on the installation elevation	
Starting at 500 m above sea level	0.44 A _{eff} per 1000 m
Peak current	24 A _{eff}
Nominal switching frequency	20 kHz
Possible switching frequencies	5 / 10 / 20 kHz
Electrical stress of the connected motor in accordance with IEC TS 60034-25 ⁸⁾	Limit value curve A
Max. motor line length	25 m
Protective measures	
Overload protection	Yes
Short circuit and ground fault protection	Yes
Max. output frequency	598 Hz ⁹⁾
Motor holding brake connection	
Response threshold for open line monitoring	Approx. 385 mA
Max. output current	1 A
Max. number of switching cycles	Unlimited since handled electronically
Braking resistors	
Peak power output	7 kW
Continuous power	200 W
Limit switch and reference inputs	
Quantity	3

Table 2: 8V1045.00-2 - Technical data

Product ID	8V1045.00-2
Wiring	Sink
Electrical isolation	
Input - ACOPOS	Yes
Input - Input	No
Input voltage	
Nominal	24 VDC
Maximum	30 VDC
Switching threshold	
Low	<5 V
High	>15 V
Input current at nominal voltage	Approx. 4 mA
Switching delay	Max. 2.0 ms
Modulation compared to ground potential	Max. ±38 V
Enable inputs	
Quantity	1
Wiring	Sink
Electrical isolation	
Input - ACOPOS	Yes
Input voltage	
Nominal	24 VDC
Maximum	30 VDC
Input current at nominal voltage	Approx. 30 mA
Switching threshold	
Low	<5 V
High	>15 V
Switching delay	
Enable 0 -> 1, ready for PWM	Max. 100 µs
Enable 1 -> 0, PWM off	Max. 2.0 ms
Modulation compared to ground potential	Max. ±38 V
OSSD signal connections ¹⁰⁾	Not permitted
Trigger inputs	
Quantity	2
Wiring	Sink
Electrical isolation	
Input - ACOPOS	Yes
Input - Input	No
Input voltage	
Nominal	24 VDC
Maximum	30 VDC
Switching threshold	
Low	<5 V
High	>15 V
Input current at nominal voltage	Approx. 10 mA
Switching delay	
Rising edge	52 µs ±0.5 µs (digitally filtered)
Falling edge	53 µs ±0.5 µs (digitally filtered)
Modulation compared to ground potential	Max. ±38 V
Electrical characteristics	
Discharge capacitance	660 nF
Operating conditions	
Permitted mounting orientations	
Hanging vertically	Yes
Lying horizontally	Yes
Standing horizontally	No
Installation at elevations above sea level	
Nominal	0 to 500 m
Maximum ¹¹⁾	2000 m
Degree of pollution in accordance with EN 61800-5-1	2 (non-conductive pollution)
Overvoltage category in accordance with EN 61800-5-1	II
EN 60529 protection	IP20
Environmental conditions	
Temperature	
Operation	
Nominal	5 to 40°C
Maximum ¹²⁾	55°C
Storage	-25 to 55°C
Transport	-25 to 70°C
Relative humidity	
Operation	5 to 85%
Storage	5 to 95%
Transport	Max. 95% at 40°C

Table 2: 8V1045.00-2 - Technical data

Product ID	8V1045.00-2
Mechanical characteristics	
Dimensions	
Width	70.5 mm
Height	375 mm
Depth	235.5 mm
Weight	4.1 kg

Table 2: 8V1045.00-2 - Technical data

- 1) In the USA, TT and TN power mains are commonly referred to as "Delta/Wye with grounded Wye neutral".
- 2) If the module is operated with a mains input voltage of 3x 230 VAC, then automatic nominal voltage detection doesn't work for the DC bus. The UDC_NOMINAL parameter must be set to 325 [V] by the user in this case.
- 3) Limit values from EN 61800-3 C3 (second environment).
- 4) The permissible input voltage range is reduced when using motor holding brakes. The input voltage range should be selected so that the proper supply voltage for the motor holding brake can be maintained.
- 5) The current consumption depends on the configuration of the ACOPOS servo drive.
- 6) Valid in the following conditions: 400 VAC mains input voltage, nominal switching frequency, 40°C ambient temperature, installation elevation <500 m above sea level.
- 7) Value for the nominal switching frequency.
- 8) If necessary, the stress of the motor isolation system can be reduced by an additional externally wired dv/dt choke. For example, the RWK 305 three-phase dv/dt choke from Schaffner (www.schaffner.com) can be used. Important: Even when using a dv/dt choke, it is necessary to ensure that an EMC-compatible, low inductance shield connection is used!
- 9) The module's electrical output frequency (SCTRL_SPEED_ACT * MOTOR_POLEPAIRS) is monitored to protect against dual use in accordance with EC regulation 428/2009 | 3A225. If the electrical output frequency of the module exceeds the limit value of 598 Hz uninterrupted for more than 0.5 s, then the current movement is aborted and error 6060 is output (Power element: Limit speed exceeded).
- 10) OSSD (open signal switching device) signals are used to monitor signal lines for short circuits and cross faults.
- 11) Continuous operation of ACOPOS servo drives at elevations ranging from 500 m to 2000 m above sea level is possible (taking the specified continuous current reductions into consideration).
- 12) Continuous operation of ACOPOS servo drives at ambient temperatures ranging from 40°C to max. 55°C is possible (taking the specified continuous current reductions into consideration), but this will result in a shorter service life.

4 Status indicators

ACOPOS servo drives are equipped with three LEDs for direct diagnostics:

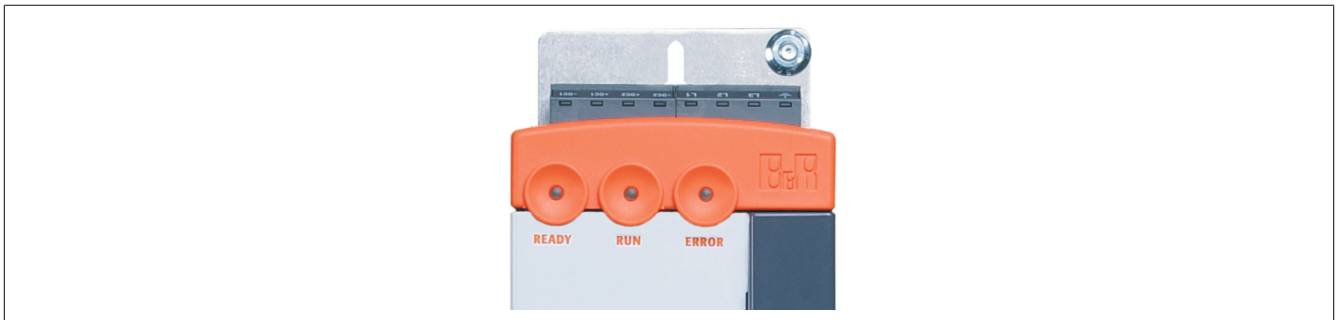

Figure 1: ACOPOS servo drives - Status indicators

Labeling	Color	Function	Description	
READY	Green	Ready	Green (lit)	The module is operational and the power stage can be enabled (operating system present and booted, no permanent or temporary errors).
			Green (blinking) ¹⁾	The module is not ready for operation. <u>Examples:</u> <ul style="list-style-type: none"> • No signal on one or both enable inputs • DC bus voltage outside the tolerance range • Overtemperature on the motor (temperature sensor) • Motor feedback not connected or defective • Motor temperature sensor not connected or defective • Overtemperature on the module (IGBT junction, heat sink, etc.) • Disturbance on network
RUN	Orange	Run	Orange (lit)	The module's power stage is enabled.
ERROR	Red	Error	Red (lit) ¹⁾	There is a permanent error on the module. <u>Examples:</u> <ul style="list-style-type: none"> • Permanent overcurrent • Invalid data in EPROM

Table 3: LED status - ACOPOS servo drives

- 1) Firmware V2.130 and higher

If no LEDs are lit, the ACOPOS servo drive is not being supplied with 24 VDC.

Danger!

After switching off the device, wait until the DC bus discharge time of at least five minutes has passed. The voltage currently on the DC bus must be measured with a suitable measuring device before beginning work. This voltage must be less than 42 VDC to rule out danger. An unlit Run LED does not indicate that voltage is not present on the device!

4.1 LED status

The following timing is used for the indication diagrams:

Block size: 125 ms

Repeats after: 3000 ms

Status changes when booting the operating system loader

Status	LED	Display
1. Boot procedure for base hardware active	Green	
	Orange	
	Red	
2. Configuration of network plug-in module active	Green	
	Orange	
	Red	
3. Waiting for network telegram	Green	
	Orange	
	Red	
4. Network communication active	Green	
	Orange	
	Red	

Table 4: Status changes when booting the operating system loader

Error status with reference to the CAN plug-in module AC110

Status	LED	Display
Invalid hardware ID ¹⁾	Green	
	Orange	
	Red	
Boot error on CAN basic hardware	Green	
	Orange	
	Red	
Bus Off	Green	
	Orange	
	Red	
CAN station number is 0	Green	
	Orange	
	Red	

Table 5: Error status with reference to the CAN plug-in module AC110

- 1) Possible errors:
- ACOPOS servo drive defect
 - Plug-in module defect
 - Plug-in module not inserted correctly in the slot

Error status with reference to the POWERLINK V2 plug-in module AC114

Status	LED	Display
Invalid hardware ID ¹⁾	Green	[Green bar]
	Orange	[Green bar]
	Red	[Red bar]
Boot error on POWERLINK basic hardware	Green	[Green bar]
	Orange	[Green bar]
	Red	[Red bar]
Error when booting the AC114-ARM	Green	[Green bar]
	Orange	[Green bar]
	Red	[Red bar]
POWERLINK station number is 0	Green	[Green bar]
	Orange	[Green bar]
	Red	[Red bar]

Table 6: Error status with reference to the POWERLINK V2 plug-in module AC114

- 1) Possible errors:
- ACOPOS servo drive defect (plug-in module not recognized)
 - Plug-in module defect
 - Plug-in module not inserted correctly in the slot
 - Plug-in module functioning but not automatically recognized by the ACOPOS servo drive (old bootstrap loader)

5 Dimension diagram and installation dimensions

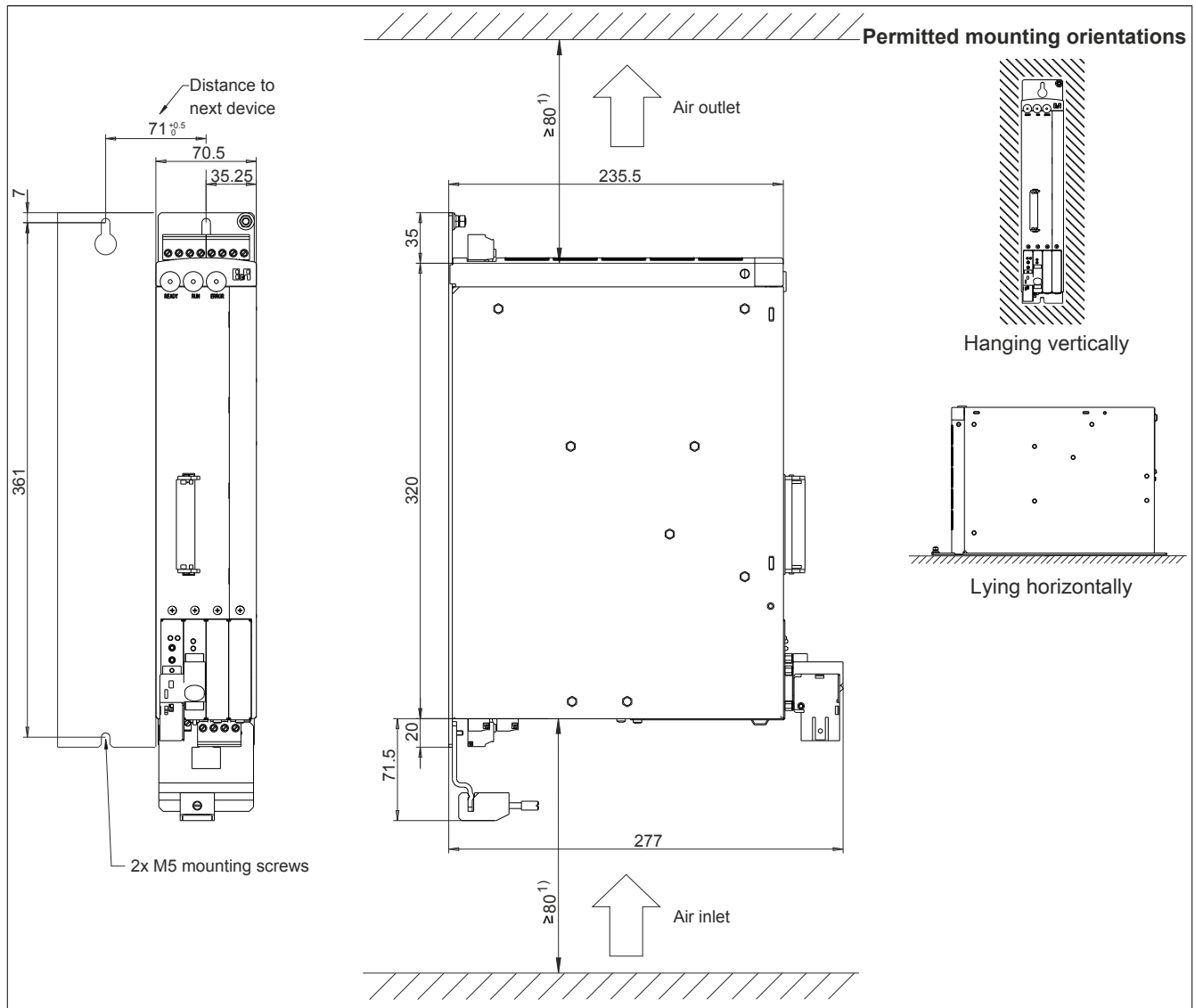

Figure 2: Dimension diagram and installation dimensions

- 1) For proper air circulation, at least 80 mm clearance must be available above and below the ACOPOS servo drive.

6 Wiring

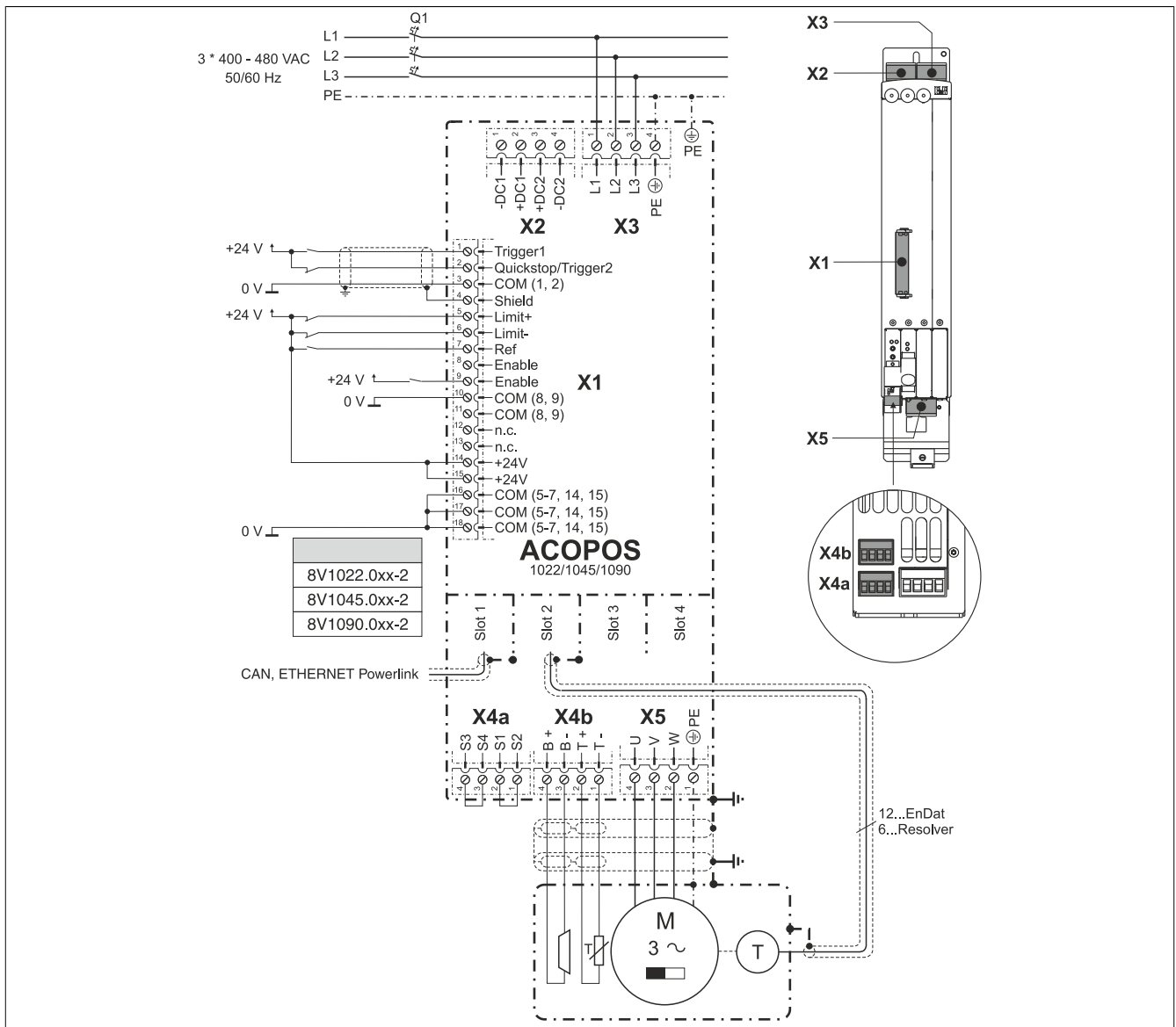



Figure 3: ACOPOS 1022, 1045, 1090 - Pinout overview

6.1 X1 - Pinout

X1	Pin	Name	Function
	1	Trigger1	Trigger 1
	2	Quickstop/Trigger2	Quickstop/Trigger2
	3	COM (1, 2)	Trigger 1, Quickstop/Trigger 2 0 V
	4	Shield	Shield
	5	Limit+	Positive HW limit
	6	Limit-	Negative HW limit
	7	Ref	Reference switch
	8	Enable ¹⁾	Enable
	9	Enable ¹⁾	Enable
	10	COM (8, 9)	Enable 0 V
	11	COM (8, 9)	Enable 0 V
	12	---	---
	13	---	---
	14	+24 V	+24 V supply
	15	+24 V	+24 V supply
	16	COM (5-7, 14, 15)	0 V supply
	17	COM (5-7, 14, 15)	0 V supply
	18	COM (5-7, 14, 15)	0 V supply

The following connections are linked with each other internally in the device:

- Pin 8 --> Pin 9 (Enable)
- Pin 10 --> Pin 11 (Enable 0 V)
- Pin 14 --> Pin 15 (Supply +24 V)
- Pin 16 --> Pin 17 --> Pin 18 (Supply 0 V)

Table 7: X1 - Pinout

1) The wiring is not permitted to exceed a total length of 30 m.

6.2 X2 - Pinout

X2	Pin	Name	Function
	1	-DC1	U DC bus -
	2	+DC1	U DC bus +
	3	+DC2	U DC bus +
	4	-DC2	U DC bus -

Table 8: X2 - Pinout

6.3 X3 - Pinout

Danger!

Servo drives are not permitted to be operated directly on IT and TN-S mains with a grounded phase conductor and protective ground conductor!

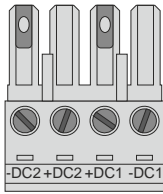
X3	Pin	Name	Function
	1	L1	Power mains connection L1
	2	L2	Power mains connection L2
	3	L3	Power mains connection L3
	4	PE	Protective ground conductor

Table 9: X3 - Pinout

6.4 X4a, X4b - Pinout

X4a	Pin	Name	Function
	1	S2 ¹⁾	Activation, supply for the external holding brake (+)
	2	S1 ¹⁾	Activation for the external holding brake (+)
	3	P4	Activation, supply for the external holding brake (-)
	4	S3	Activation for the external holding brake (-)

Table 10: X4a - Pinout

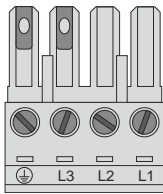
- 1) If the holding brake is connected via an additional external relay contact (ground-in e.g. via the connections S1/S2) instead of via the internal transistor, then the internal quenching circuit has no effect! In this case, the customer must make sure that neither the relay contact nor the braking coil are damaged when switching off the brake. This can be done by interconnecting the coil or - better still - interconnecting the contact with a quenching circuit.

X4b	Pin	Name	Function
	1	T-	Temperature sensor -
	2	T+	Temperature sensor +
	3	B- ¹⁾	Brake -
	4	B+ ¹⁾	Brake +

Table 11: X4b - Pinout

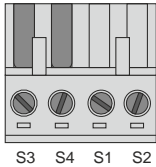
- 1) If the holding brake is connected via an additional external relay contact (ground-in e.g. via the connections S1/S2) instead of via the internal transistor, then the internal quenching circuit has no effect! In this case, the customer must make sure that neither the relay contact nor the braking coil are damaged when switching off the brake. This can be done by interconnecting the coil or - better still - interconnecting the contact with a quenching circuit.

Danger!

The connections for the motor temperature sensors and the motor holding brake are isolated circuits. Therefore, these connections are only allowed to be connected to devices or components with at least safe isolation in accordance with IEC 60364-4-41 or EN 61800-5-1.

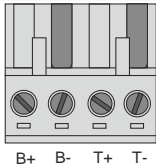
Caution!

If B+ and B- are swapped when connecting the permanent magnet holding brakes, then the brakes cannot be opened! ACOPOS servo drives cannot determine if a holding brake is connected with reverse polarity!

6.4.1 Wiring the connections for the motor holding brake

The supply, activation and monitoring of the output for the motor holding brake can take place via the X4a connector in three different ways:

	Figure	Description
1		<ul style="list-style-type: none"> • Supply: Internally by the ACOPOS servo drive • Activation: Internally by the ACOPOS servo drive • Monitoring: Internally by the ACOPOS servo drive <p>A jumper must be placed between S1 and S2 as well as S3 and S4 on the X4a connector. ¹⁾</p>
2		<ul style="list-style-type: none"> • Supply: Internally by the ACOPOS servo drive • Activation: Internally by the ACOPOS servo drive and also possible externally using potential-free contacts ²⁾ • Monitoring: Internally by the ACOPOS servo drive <p>Information: The parameters for internal monitoring via the ACOPOS must be set according to the requirements of the application. ³⁾</p>
3		<ul style="list-style-type: none"> • Supply: External • Activation: External • Monitoring: External <p>Information: ACOPOS internal monitoring cannot be used here; therefore, it must be disabled using software. ⁴⁾</p>

Table 12: Activation for the external holding brake

- 1) Both jumpers are already on the X4a connector delivered with the ACOPOS servo drives.
- 2) External potential-free contacts can be connected between S1 and S2 as well as between S3 and S4. This makes it possible to activate the holding brake using an external safety circuit independent of the control integrated in the ACOPOS servo drive.
- 3) The parameters are set using ParID 90 (1 ... internal monitoring active; 5 ... internal monitoring not active).
- 4) Deactivation takes place using ParID 90 (5 ... internal monitoring not active).

6.5 X5 - Pinout

X5	Pin	Name	Function
	1	PE	Protective ground conductor
	2	W	Motor connection W
	3	V	Motor connection V
	4	U	Motor connection U

Table 13: X5 - Pinout

6.6 Additional protective ground connection (PE)

The protective ground conductor is connected to the M5 threaded bolt provided using a cable lug.

Figure	Pin	Name	Function
	---	PE	Protective ground conductor
Terminal cross sections		[mm²]	AWG
Cable lug for M5 threaded bolt		0.25 - 16	23 - 5

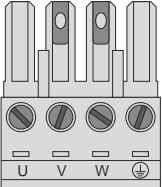
Table 14: Protective ground conductor (PE) ACOPOS 1022, 1045, 1090

Danger!

Before turning on the servo drive, make sure that the housing is properly connected to ground (PE rail). The ground connection must be established even when testing the drive or operating it for a short time!

6.7 Input/Output circuit diagram

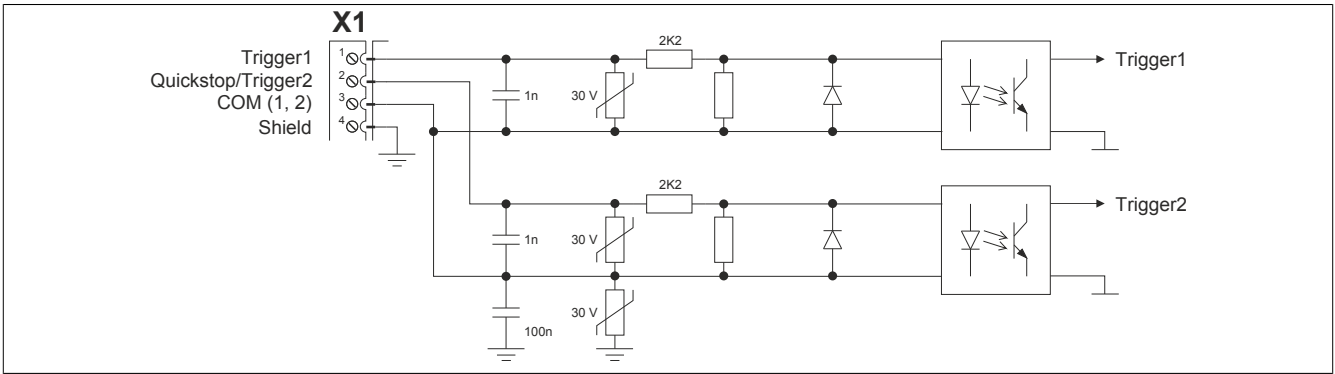

Figure 4: Trigger

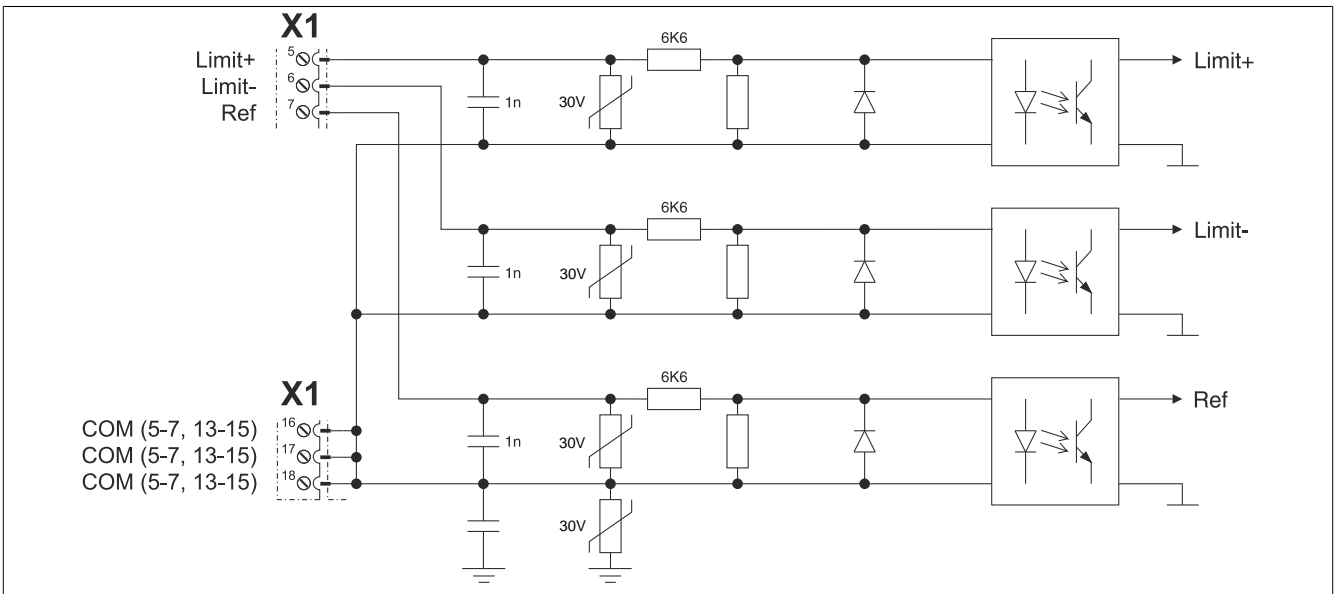

Figure 5: Limit

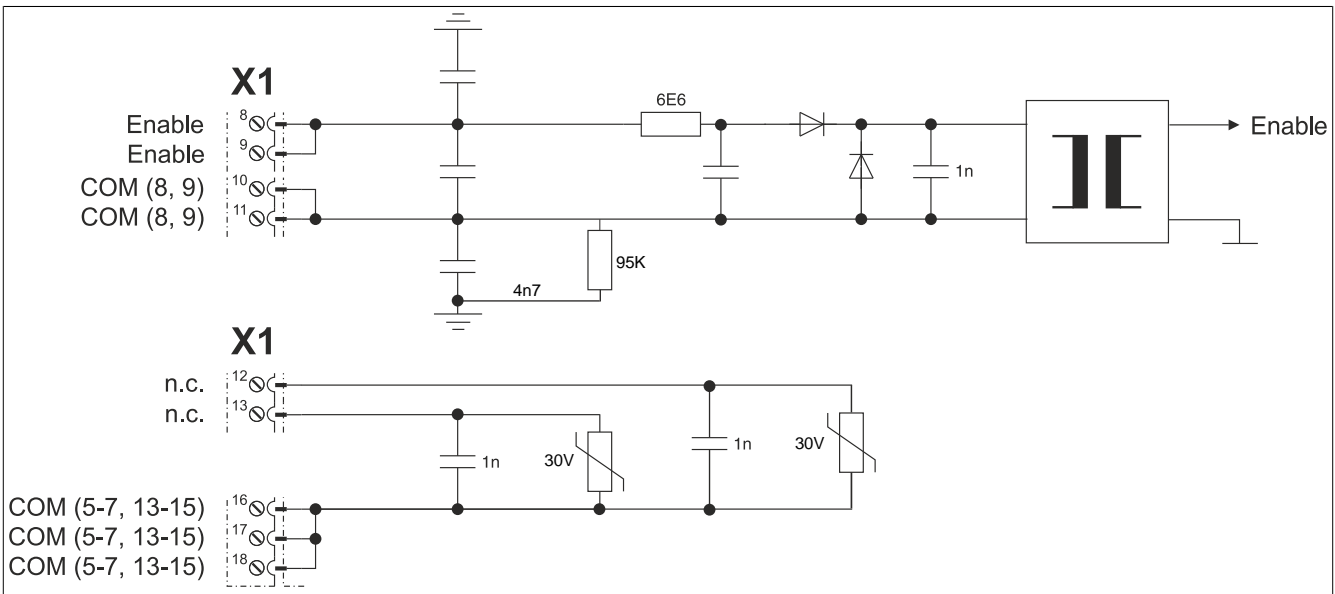

Figure 6: Enable

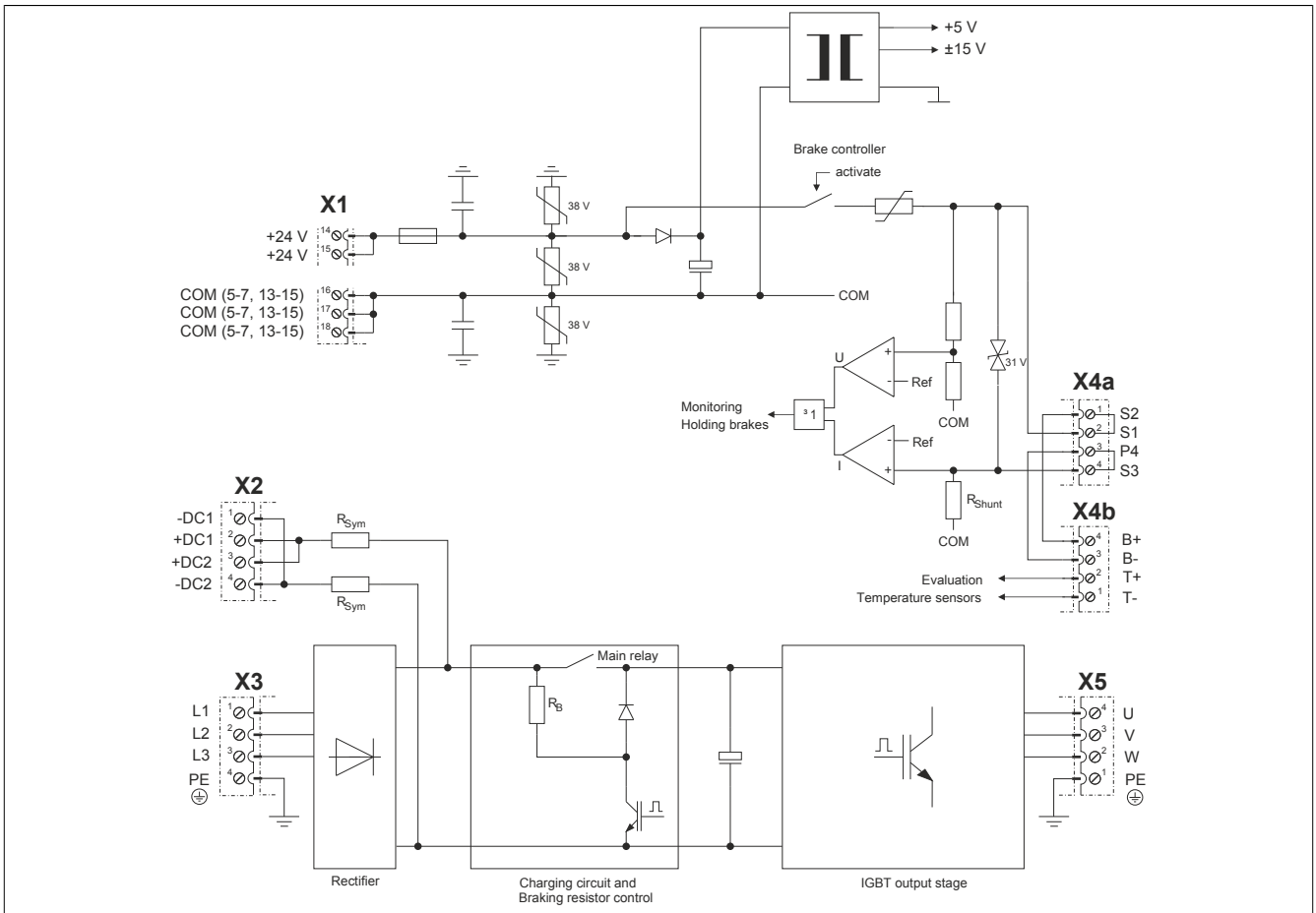

Figure 7: ACOPOS 1022, 1045, 1090 - Input/Output circuit diagram